

Sportsman/Scrambler 1000 Stage 2 Trail kit

Primary adjustment tip, this will get you started adjusting the clutch.

More tip weights increase the shift rpm, more heel weight lowers the engagement rpm and gives better acceleration. More weights usually lowers peak rpm, less weight increase peak rpm.

Weight arms is adjustable, allowing you to adjust the weight arm mass and get the machine in best peak rpm.

The following images will help you adjust your clutch.

Let's say top end on your machine is mean to be 130kmh (80mph). Simply divide your weight into imaginary thirds. The first third controls the RPMs for 0-44kmh (0-27mph), second third controls RPMs for 44-88kmh (27-54mph) and the final third controls RPMs for 88-130kmh (54-80mph).

You add or subtract weight to each section to make sure the engine RPMs are consistently at peak RPM for each 1/3 range.

Look at the charts, they will help you understand how to move the weight around to achieve the desired results.

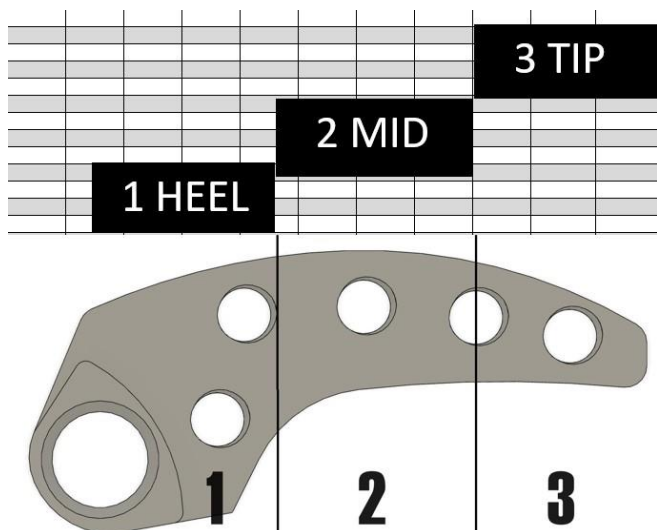

You can start adjusting from the image below. Don't be overly concerned about exact weight placement at this time, it's only starting point. Your machine should run in most cases 7200-7400rpm.

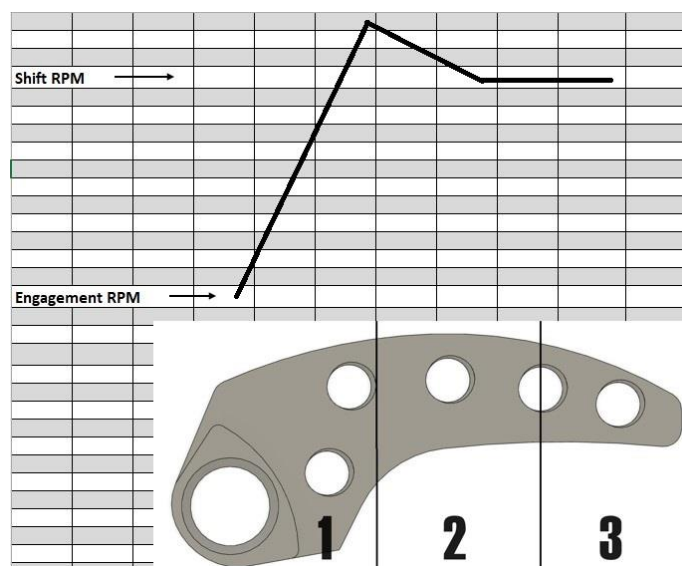
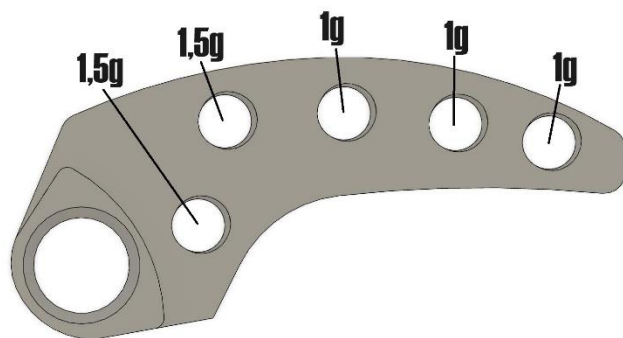

Too light heel, add more weight 1.

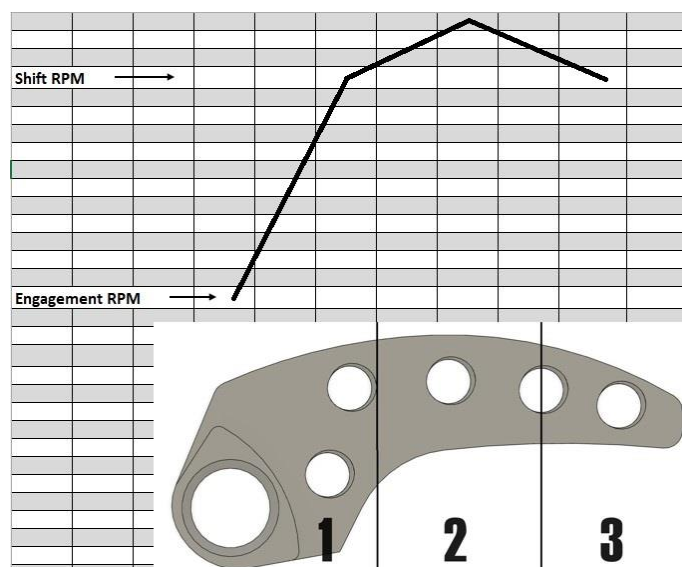

Too light midrange, add more weight 2.

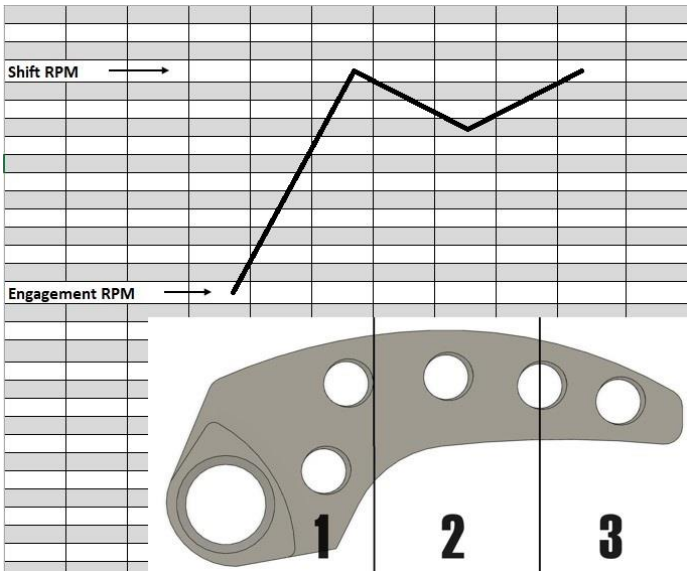

Too heavy midrange, less weight 2.

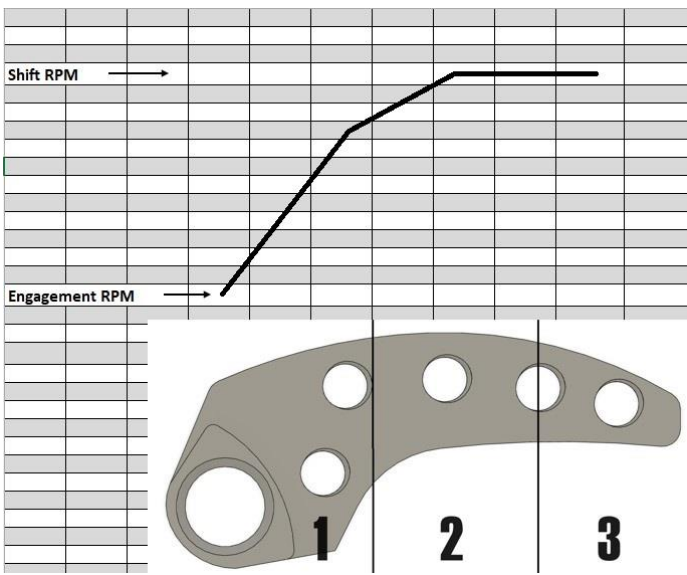

Too heavy heel, less weight 1.



ROUSTA
POWERLINE